

JBL

PRO POWER™

GTi

Automotive Amplifier Owner's Manual

A302GTi

A601GTi

A1201GTi

Thank you for purchasing a JBL GTi Series amplifier. In order that we may better serve you, should you require warranty service on your new amplifier, please retain your original purchase receipt and return the enclosed warranty registration card.

Warning: Playing loud music in an automobile can hinder your ability to hear traffic as well as permanently damage your hearing. We recommend listening at low levels while driving. JBL accepts no liability for hearing loss, bodily injury or property damage resulting from use or misuse of this product.

Important: Installation of automotive stereo components can require extensive experience in performing a variety of mechanical and electrical procedures. Although these instructions explain how to install GTi Series amplifiers in a general sense, they may not show the exact installation methods for your particular vehicle. If you feel you lack the tools or experience necessary, ask your authorized JBL car audio dealer about professional installation options.

Installation Warnings and Tips

- Always wear protective eyewear when using tools.
- Turn off all audio systems and other electrical devices before you start. Disconnect the (-) negative lead from your vehicle's battery.
- Check clearances on both sides of a planned mounting surface before drilling any holes or installing any screws. Remember that the screws can extend behind the surface.
- At the installation sites, locate and make a note of all fuel lines, hydraulic brake lines, vacuum lines and electrical wiring. Use extreme caution when cutting or drilling in and around these areas.
- Before drilling or cutting holes, use a utility knife to remove unwanted fabric or vinyl to keep material from snagging in a drill bit.
- When routing cables, keep input signal cables away from power cables and speaker wires.
- When making connections, ensure that they are secure and properly insulated.
- If the amplifier's fuse must be replaced, use only the same type and rating as a replacement. Do not substitute another kind.

Choosing a Location and Mounting the Amplifier

Amplifiers need air to stay cool. Suitable mounting locations are under seats (provided the amplifier doesn't interfere with the seat adjustment mechanism), in the trunk or in any other location that provides enough air for the amp to cool itself. Do not mount the amplifier with the heatsink facing downward, as this makes convection cooling of the amplifier impossible.

Mount the amplifier so that it is not damaged by the feet of back-seat passengers or by the shifting of cargo in the trunk. Mount the amplifier so that it remains dry – never mount an amplifier outside the car or in the engine compartment.

Using the amplifier as a template, mark the location of the mounting holes on the mounting surface, drill pilot holes, and attach the amplifier to the mounting surface using screws. Make sure the amplifier is mounted securely.

Figure 1. Connecting the A1201GTi and A601GTi

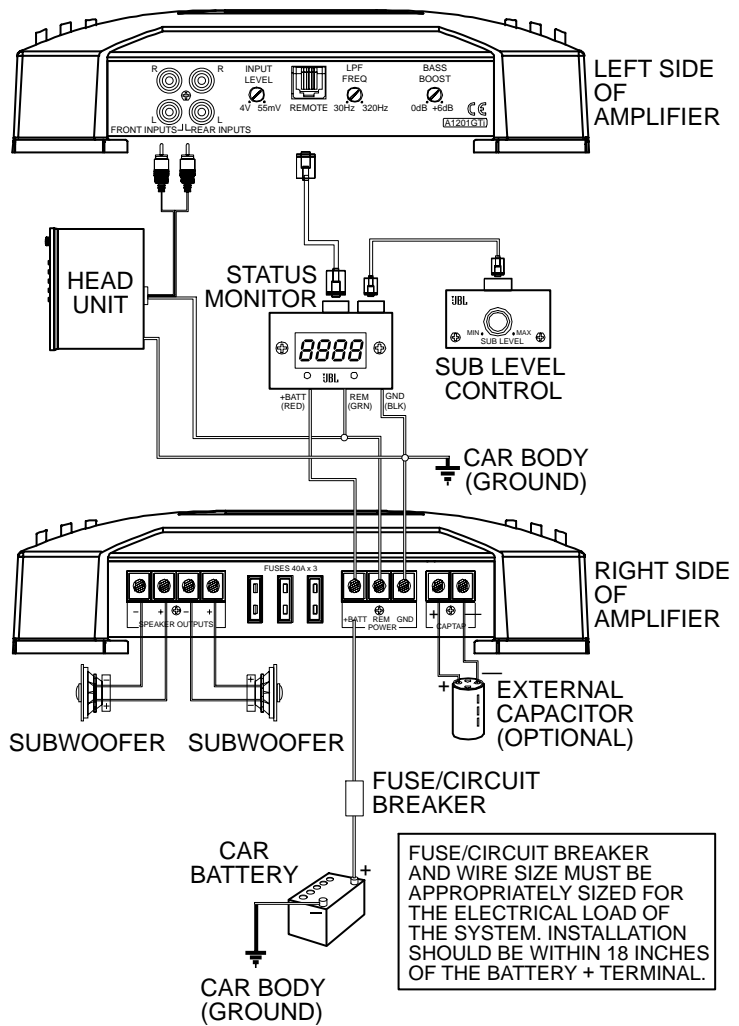
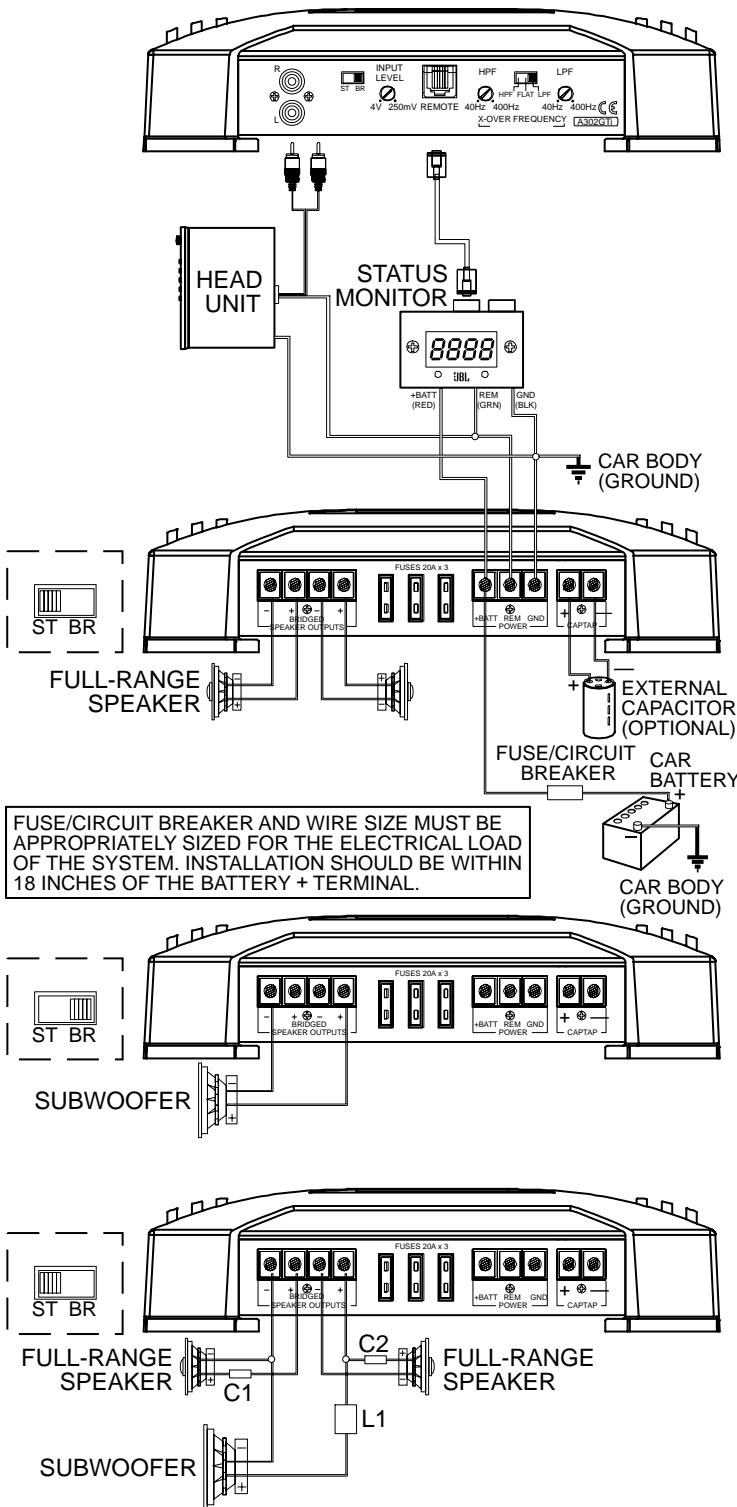

Figure 2. Connecting the A302GTi



Wiring the Power Connections

Refer to Figures 1 and 2 for connector locations. All the GTi Series amplifiers will accept up to 4-gauge power and ground wire. To determine the minimum acceptable power and ground wire, consult the chart below.

Length*	A302GTi	A601GTi	A1201GTi
4 Ft.	8-Gauge	8-Gauge	8-Gauge
4-7 Ft.	8-Gauge	8-Gauge	8-Gauge
7-10 Ft.	8-Gauge	8-Gauge	8-Gauge
13-16 Ft.	4-Gauge	8-Gauge	4-Gauge
16-19 Ft.	4-Gauge	4-Gauge	4-Gauge

*Length of wire to be used.

For Power, Remote and Ground connections, strip off one end of each jacket to reveal bare wire for insertion into the connectors. Connect a wire from the GND connector on the amplifier to the nearest bare-metal chassis component – you should scrape away the paint to ensure good conductivity. Next, connect a wire between the BATT terminal on the amplifier and the POS (+) terminal of the vehicle's battery. Pass the wire through a factory-installed grommet in the firewall, or install a grommet if a factory grommet is not available. You must install an in-line fuseholder and a fuse within 18 inches of the vehicle's battery. The fuse you install must have at least the same amperage rating as the sum of the amperage ratings of the fuses in the amp's chassis. This will protect the vehicle in case of a short circuit. Connect a wire between the REM terminal of the amplifier and the "remote out" lead on the vehicle's radio. If your radio does not provide a "remote out" lead, the REM terminal may be connected to the radio's ignition lead.

Connecting an Optional Stiffening Capacitor

You may connect an optional outboard stiffening capacitor (sold as an accessory at many car audio dealers) to your GTi Series amplifier. For best performance, mount the capacitor as close to the amp as possible, using the shortest wires possible to connect the capacitor to the CapTap™ connections on the amplifier. Choose the wire gauge according to the chart on page 3. Make sure to connect the capacitor observing proper polarity. Failure to observe proper polarity may cause damage to the capacitor and/or the amplifier. Use at least a 1-Farad capacitor, or a combination of smaller capacitors, connected in parallel, that have a total capacitance equal to or greater than 1 Farad, for an A1201GTi and A302GTi. Use at least a 500uF capacitor or combination of capacitors in parallel for the A601GTi. Use the following formula to determine the total capacitance of several capacitors connected in parallel:

$$C_t = C_1 + C_2 + C_3 \dots$$

Where C_t is total capacitance and C_1 , C_2 and C_3 are the capacitance values of the individual capacitors connected in parallel.

Note: If you must use several smaller caps in parallel, use caps of equal value.

Wiring the Speaker Output Connections

All the GTi Series amplifiers will accept up to 8-gauge speaker wire.

A302GTi

Connect the speakers observing proper polarity to the speaker output connector. The total nominal impedance of the speaker system connected to the amplifier when the amplifier is driven in stereo must be at least 2 ohms.

If you are bridging the amplifier, connect the speaker wires to the terminals marked "bridged", observing proper polarity. The total nominal impedance of the speaker system connected to the amplifier must be at least 4 ohms in bridged mode.

If you are running the amp in Tri-Mode (stereo and mono simultaneously): Connect the satellite speakers to the speaker connector as you would a pair of stereo speakers. Connect the subwoofer to the terminals marked "bridged". Refer to the chart below to determine the capacitor and inductor values you'll need to route bass signals to the woofer, and midrange and high frequencies to the satellite speakers. These passive crossover components will also ensure that the impedance of the speaker system doesn't drop below 2 ohms.

FREQUENCY	INDUCTOR	CAPACITOR
Crossover	6dB/oct. LP (4-ohm)	6dB/oct. HP (4-ohm)
75Hz	80mH	530µF
100Hz	6.4mH	400µF
125Hz	5.0mH	318µF
150Hz	4.2mH	265µF
175Hz	3.6mH	227µF
200Hz	3.2mH	198µF

A1201GTi, A601GTi

Connect the woofers to the amplifier observing proper polarity. Although these amplifiers have a single channel, duplicate positive and negative connectors are provided to facilitate the connection of multiple woofers. You may use either + terminal and either - terminal on the amplifier.

Wiring the Input Signal Connections

Connect a pair of signal cables with RCA-type connectors between the RCA-type input connectors on the amplifier and the RCA-type output connectors on the source unit.

The A1201GTi and A601GTi have been designed to provide constant bass regardless of the position of the source unit's front to rear fader. Use of this feature requires that all four inputs are connected to the source unit as labeled on the amplifier: front, rear, right and left. If nonfading bass is not important in your system, connect a pair of inputs to either the front or rear input connectors on the amplifier.

Installing the Remote Level Control (A1201GTi and A601GTi only) and Status Monitor

Choose a suitable location for the status monitor. There must be at least 2" clearance behind the mounting surface. Cut a rectangular hole 3-1/4" by 1-5/8". Connect the red wire to a constant 12V+ source, the black wire to ground and the green wire to the remote turn-on wire from the head unit. Connect the RJ45 cable between the amplifier and the status monitor. Connect the RJ11 cable between the status monitor and the remote level control. Turn the screws located on the front panel clockwise to engage the mounting tabs and continue turning the screws clockwise to tighten the status monitor in its location. See Figure 3 below.

Figure 3. Mounting the status monitor

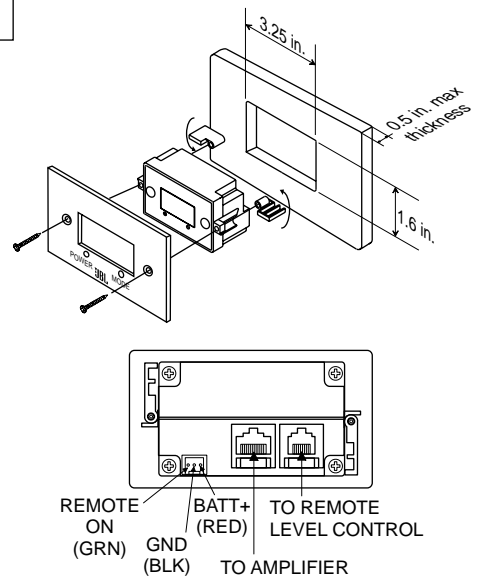
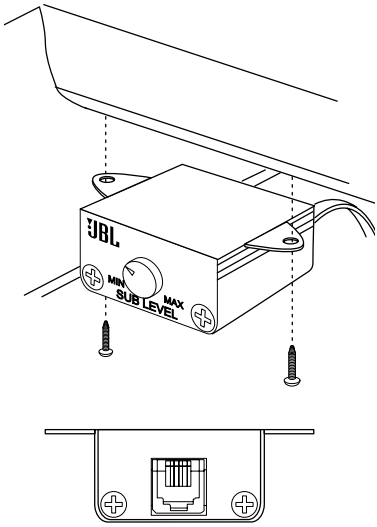

Figure 4. Mounting the level control



Installing the Remote Level Control (A1201GTi and A601GTi only) and Status Monitor

Choose a location for the remote level control that is within your reach while you are seated in the driving position. Attach the level control to the mounting surface using screws through the mounting tabs, as shown in Figure 4. Connect the RJ11 cable between the status monitor and the remote level control.

Note: In order to use the remote level control with the A1201GTi or the A601GTi, the status monitor must be installed. The remote level control will not work with the A302GTi.

Controlling More Than One A601GTi or A1201GTi With a Single Remote Level Control

In order to control several GTi Series amplifiers with a single level control, you must purchase an RJ11 splitter, several splitters or a break-out box. These adapters are available at many stores that sell telephone accessories. Up to five amplifiers may be controlled with a single level control. In addition to the RJ11 adapters, you must also purchase RCA-type "Y" adapters to provide input signal to each of the amplifiers. See Figure 5 below for connections.

Figure 5. Controlling multiple amps with a single level control

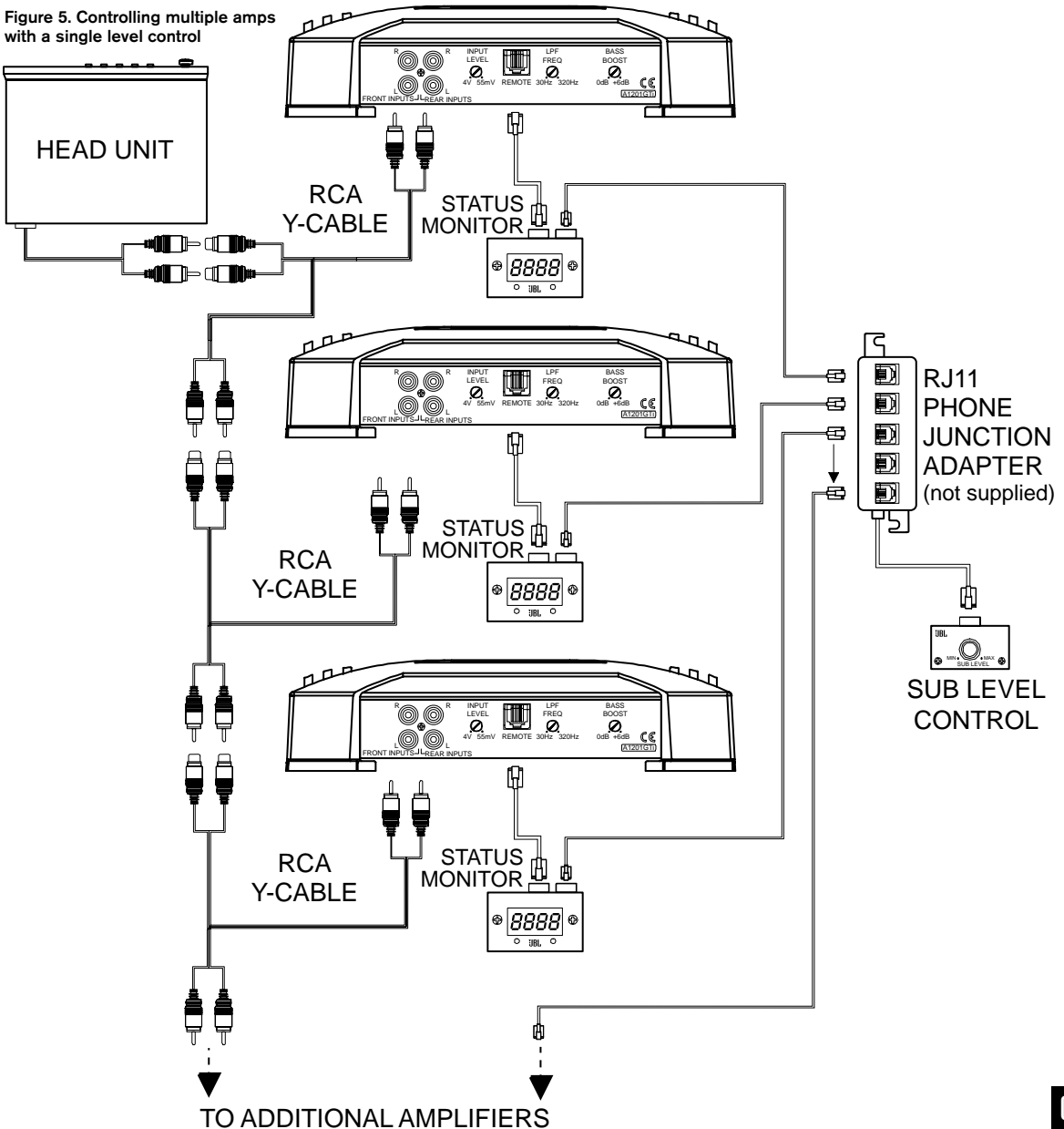

System Set-Up and Adjustment

Programming and Using the Status Monitor

In order for the status monitor to display the correct data, it must be programmed. Follow the sequence below after the amplifier(s) has been installed. Refer to Figure 3 for the location of the controls.

1. While pressing the Power button, turn on the head unit.
2. Select the appropriate amplifier by repeatedly pressing the "mode" button. A601GTi is abbreviated as A601. A1201GTi is abbreviated as A12k, and A302GTi is abbreviated as A302.
3. Press "Power" to confirm your selection. The status monitor will display "OK".
4. Press the "Mode" button to select a value that most closely corresponds to the nominal impedance of the speaker system connected to your amp. For the A302GTi, choose the value that corresponds to the impedance of either channel. This information must be correct in order for the monitor to correctly calculate output power.
5. Press "Power" to confirm your selection. The status monitor will display "End" to indicate that programming is complete.

During amplifier operation, press the "Mode" button repeatedly to scroll through the available information. The status monitor will display output power in Watts, input current in Amperes, input voltage, heatsink temperature (measured near the output devices) in F° or C°.

Adjusting Amplifier Input Level, Crossover and Bass Boost

Setting Input Level

Initially, turn the input level control to its fully counterclockwise position. Turn on the source unit, and increase the volume control until it is approximately 3/4 of maximum output level. Slowly turn the input level control (clockwise) while listening to the quality of the reproduced sound. When you hear distortion on the music peaks, turn the level control back slightly. This is the maximum undistorted output level of your system. Turning the level control up past this level WILL NOT INCREASE THE MAXIMUM OUTPUT POWER OF YOUR AMPLIFIER! It will only decrease the amount of volume control rotation before the amp is at full output power. It will also increase the amount of extraneous noise present in your system.

Setting the Crossover

A1201GTi and A601GTi

The 24dB/octave low-pass filter built into your A1201GTi or A601GTi can be adjusted to any frequency between 32Hz and 320Hz. You should choose a crossover frequency that prevents vocals and other midrange information from being reproduced by your subwoofer. Turning the knob counterclockwise will decrease the crossover frequency and turning it clockwise will increase it.

A302GTi

The 24dB/octave crossover built into your A302GTi can be selected as a low-pass filter (LPF), a high-pass filter (HPF) or it may be defeated (Flat). If your A302GTi will be used to drive subwoofers, select LPF and adjust the crossover according to the instructions above for the A1201GTi and A601GTi. If your A302GTi will be used to drive midrange and high-frequency speakers, you should set the crossover as HPF and select a frequency that minimizes the distortion present in the speaker's output while allowing the speaker to produce as much low-frequency information as it can with minimum distortion. Adjust the crossover frequency after setting the level control as described above. If your A302GTi will be used to drive midrange and high-frequency speakers as well as a subwoofer, defeat the crossover (Flat).

Setting the Bass Boost (A601GTi and A1201GTi)

Use this control to add as much as 6dB of boost at 50Hz. You may set this control according to your preference.

Troubleshooting

Symptom	Likely Cause	Solution
No audio (Red LED flashes every four seconds)	Short circuit in speaker or speaker wire.	Disconnect speaker leads one at a time to determine which speaker or wire is shorted or defective. Repair the short circuit or replace bad speaker.
No audio (Power indicator is off)	No voltage at BATT or REM terminals. Bad or no ground connection.	Check voltage at amplifier terminals with VOM.
No audio (Green power LED is lit)	Amplifier overheated.	Make sure amplifier cooling isn't prevented by mounting location. Make sure speaker-system impedance is within limit (see Specifications).
No audio (Red LED stays lit)	Excessive voltage on B (+) connection.	Check vehicle charging system for defective voltage regulator.
Distorted audio	Input sensitivity not set properly; amplifier or source unit defective.	Check LEVEL setting.
Music lacks "punch"	Speakers are not connected properly.	Check speaker connections for proper polarity.
Status monitor fails to turn on	No power to meter, or cable disconnected.	Check connections to monitor and amplifier. Check power on red and green wires, ground on black wire.
Status monitor displays erroneous readings	Status monitor programmed incorrectly.	Reprogram status monitor.
Remote level control doesn't work or has small range of adjustment	Cable disconnected or amp level set too low.	Check connections to level control; set amp level control higher.

Declaration of Conformity



We, Harman Consumer International
2, route de Tours
72500 Chateau-du-Loir
FRANCE

declare in own responsibility, that the products described in this owner's manual are in compliance with technical standards:

EN 55013/A12/8.1994
EN 55020/12.1994



Lutz Uphoff
Harman Consumer International
Chateau-du-Loir, FRANCE. 10/00

Specifications

	A302GTi	A601GTi	A1201GTi
Number of channels	2	1	1
Output power @ 4 ohms	150W RMS x 2	300W RMS x 1	600W RMS x 1
Output power @ 2 ohms	300W RMS x 2	600W RMS x 1	1200W RMS x 1
Output power bridged	600W RMS x 1		
Stable into	2 Ohms (4 Ohms bridged)	1 Ohm	1 Ohm
Frequency response	10Hz~40kHz	20Hz~320Hz	20Hz~320Hz
THD at rated power	0.03%	0.10%	0.10%
Signal-to-noise ratio	>110dB	>90dB	>90dB
Maximum current draw	80A	60A	117A
Fuse rating	3 x 20A	2 x 30A	3 x 40A
Remote on voltage	5V DC	5V DC	5V DC
Input sensitivity	250mV – 4V	250mV – 4V	250mV – 4V
Crossover slope	24dB/Oct.	24dB/Oct.	24dB/Oct.
Crossover frequency	40Hz~400Hz	32Hz~320Hz	32Hz~320Hz
Bass boost	None	0 to +6dB @ 50Hz	0 to +6dB @ 50Hz
Dimensions	10-3/16" x 14-13/16" x 2-11/16" (274mm x 376mm x 67.5mm)	9-1/16" x 12-9/16" x 2-1/16" (229mm x 319mm x 67.5mm)	10-3/16" x 14-13/16" x 2-11/16" (274mm x 376mm x 67.5mm)

JBL Consumer Products • 250 Crossways Park Drive, Woodbury, NY 11797
1-800-336-4JBL (4525) www.jbl.com

©2000 JBL, Incorporated • JBL is a registered trademark of JBL, Incorporated

Printed in USA Part No. A302,A601,A1201GTIOM10/00

H A Harman International Company